

Give the main use of VOIP Technology

Answer: Speaking/Talking/Video over the internet



Identify one benefit of using VOIP Technology

Answer: Can be used on smart phones/iPad/tablets OR can be used anywhere that has an internet connection. Do not mention anything to do with cost

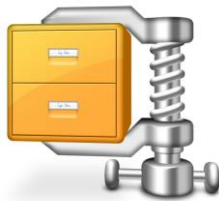

File Compression is used when transferring files, identify 2 reasons for compressing files

Answer: To achieve faster file downloads and to reduce storage space required

Outline two reasons why email can cause problems for businesses

Answer: Viruses can be spread via email attachments and employees can waste time on personal emails



Data exchange is the passing of data between computers in a network, give an example of a process used to send data

Answer: Packet Switching

Identify two secure media that can be used for storing important files

Answer: External Hard Disk and Cloud Storage



Label two missing components of this internet infrastructure diagram:

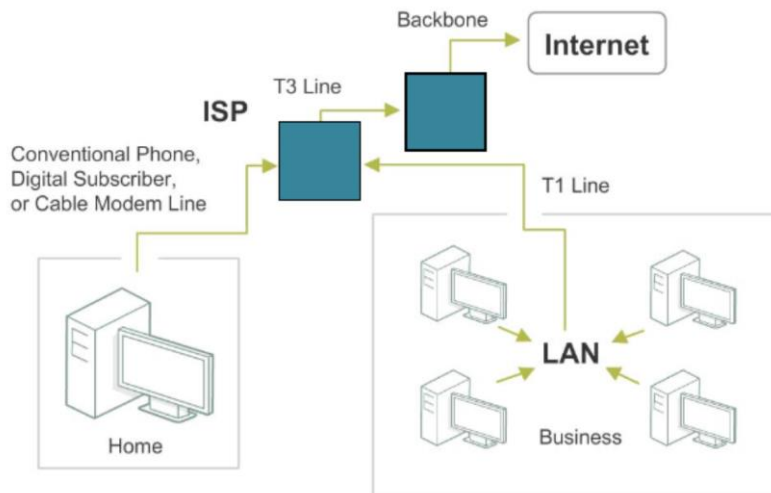

Answer: POP (left) and NAP (right)



Give two reasons why a business might use ubiquitous computing to aid stock control?

Answer: Automatically identifies when reordering is required so that user time is reduced for manual ordering.

It provides a more accurate system and eliminates human error which means that the company will benefit from fewer errors in ordering costs etc.

File Transfer Protocol (FTP) and HyperText Transfer Protocol (HTTP) are examples of application layer Internet protocols. They can both be used for downloading files. Explain two advantages of using HTTP over FTP for downloading files.

Answer: Improved security as encrypted files can be downloaded.

It saves time because a single connection can be used for multiple downloads.



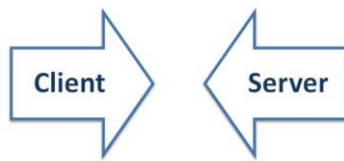

Displaying active web pages to a visitor requires both server-side and client-side processing. Input may be carried out client-side and data analysis carried out server-side. Search engines use server-side processing to carry out searches. Explain the search process carried out by a search engine.

Answer: The server searches using the keyword, which is matched against the list of websites.

Online retailers need to store large quantities of data and the data is frequently updated. Explain one reason why a relational database is necessary for online retailers.

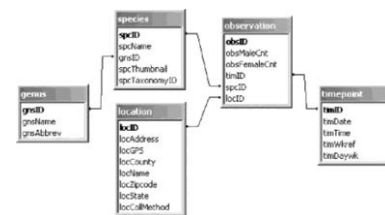

Answer: Data is organised into separate tables, which avoids duplication.



Almira is travelling to Spain to visit family. She needs to check her flight time online. Which type of online service would she use?

Answer: Realtime Information

Identify two protocols used for email communications



Answer: SMTP and POP3



Give one disadvantage to a teacher receiving a pupil's work through a VLE.

Answer: If the VLE is not working the teacher cannot access the work

Packet-switched networks transmit data in small blocks called packets. The internet is an example of a packet switched network.



Answer: Header and Trailer



Data validation is used to ensure that input data matches pre-defined criteria. There are a number of validation types that can be used to check data. Identify the validation type that checks that data has been entered.

Answer: Presence check

Aleem is concerned that when using the internet he could become a victim of phishing. Identify two measures Aleem should take to reduce the risk of phishing.



Answer: Use a firewall and anti-virus software and only use https web pages for online transactions



Internet Message Access Protocol (IMAP) is one of the standard protocols for accessing email from a remote server. Explain two advantages of using IMAP to access your emails.

Answer: Emails are stored on a central server so that users don't have to monitor email on a one particular device / everything syncs (i.e. computer and mobile phone).

Fast download and upload speeds so that large files can be sent over a slow connection.



Data encryption is vital when protecting online data. Identify two techniques for data encryption.

Answer: Symmetric encryption and asymmetric encryption

All data that travels across a network is sent in packets. Identify one component of a packet header.



Answer: Sender's IP address

Unauthorised access when using the internet can be described as 'access without damage' or 'access with damage'. Describe one method of accessing without damage.

Answer: Phishing, where you are asked for personal information such as bank details so money can be taken from the bank, but no damage is done to the computer.



A CODEC is a device or computer program capable of encoding or decoding a digital data stream or signal. Identify two reasons why CODECs are used.

Answer: Compresses video files and makes them playable on a computer.

Compresses video files to speed up download time



Dan is bidding on an online auction website to purchase an item. Explain two reasons why server-side processing is used for online auction websites.

Answer: A powerful server needs to be used rather than Dan's own computer to enable the large database to be interrogated at a reasonable speed.

The server would need to update item/bid data centrally to ensure that data is filtered to particular users.

Joe works for a car hire company that uses a relational database to store data. The example shows the three tables in the database. Explain the relationship between the Hire table and the other two tables.

Car	Hire	Customer
<u>Reg No</u>	<u>Hire ID</u>	<u>Customer ID</u>
Make	Reg No	Name
Model	Customer ID	Address
Cost	Date	Postcode
Transmission	Duration	Contact No

Answer: The Hire table is the link between the three tables as the primary key in the Car table (Reg no) is the foreign key in the Hire table whereas the primary key in the Customer table (Customer ID) is in the Hire table as a foreign key so this is how the three tables are linked.

Explain one advantage to the car hire company of using a relational database rather than a single table.

Answer: With a large single table database data is keyed in many times and could be entered incorrectly, whereas with a relational database smaller tables are created and the data is only keyed in once so less likelihood of errors.